

InSb Detectors

TECHNICAL DATA&INFORMATION

The photovoltaic **Indium Antimonide** detectors offered by **InfraRed Associates, Inc.** are p-n junctions formed by mesa techniques using single crystal material. This process yields the highest quality photodiodes which exhibit excellent electro-optical performance in the $1\mu\text{m}$ to $5.5\mu\text{m}$ wavelength region. These diodes are background



limited (BLIP) detectors and their performance can be enhanced by spatial (cooled FOV stops) or spectral (cooled interference filters) reduction of the background.

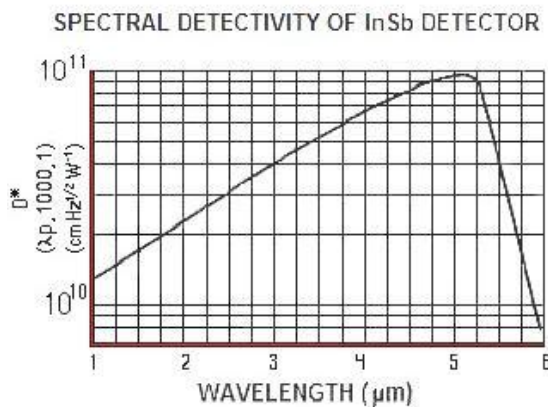

Typical Applications:

- Medical Thermography
- Thermal Imaging
- Spectroscopy
- Radiometry
- Research
- IR Microscopy

The photovoltaic effect is the generation of a potential across the p-n junction when radiation of the proper wavelength is incident upon it. When the photon flux irradiates the junction, electron-hole pairs are formed if the photon energy exceeds the forbidden gap energy.

The field sweeps the electrons from the p region to the n region, and holes from the n region to the p region. This process makes the p region positive and the n region negative, and will produce current flow in an external circuit. An equivalent circuit of the InSb detector is represented below. This consists of both a signal and noise current generator in parallel with a resistive and capacitive term.

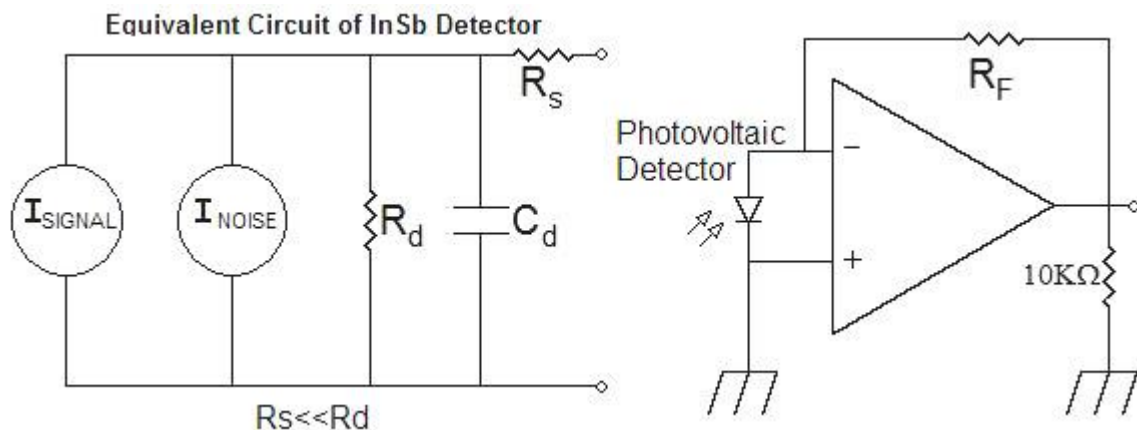

When background radiation shifts the operation curve by generating a constant output in the active element, the detector should be reversed-biased to bring it back to the optimum operating point: zero voltage.

This can be achieved by utilizing a matched preamplifier such as our IAP-1000IS. The detector preamplifier system operates in the detector noise limited mode. A dual output supply is required.

Standard Photovoltaic Indium Antimonide Detectors

Model Number	FOV=60°, (λpk,1000,1)								Std. Pkg.	Std. Window
	Active Area Element (mm)	D* (cmHz ^{1/2} W ⁻¹)	Responsivity (λp)	Resistance (Rd) (Ω)	Capacitance (Cd) (pF)	Short Circuit Current Isc (μA)	Open Circuit Voltage Vcc (mV)	Operating Temp. (K)		
IS-0.25	q.25/.25x.25	≥ 1.0E11	≥ 3 A/W	1000K	70	0.9	80 to 125	77	MSL-8 MSL-12 or MDL-8 MDL-12	Sapphire
IS-0.5	q.5/.5x.5			500K	100	2				
IS-1.0	q1/1x1			300K	350	8				
IS-2.0	q2/2x2			100K	1500	30				
MSL-8 Side Looking Metal Dewar---8 Hour Hold Time							MSL-12 Side Looking Metal Dewar---12 Hour Hold Time			
MDL-8 Down Looking Metal Dewar---8 Hour Hold Time							MDL-12 Down Looking Metal Dewar---12 Hour Hold Time			

Custom configurations and arrays designed to customer specifications are available. In addition, custom metal and glass dewars designed to function with various cooling techniques can be supplied. Contact us to discuss your specific requirements.